

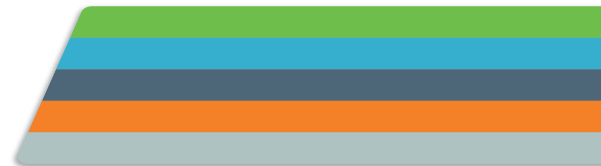

CHILLER EFFICIENCY SOLUTION

earthWISE
FULL WATER SOLUTIONS™



A Unique ECM in the Water Space

ROI of 2.5 years or less
PACE financing qualified
Local energy provider rebate qualified



The Chiller Efficiency Solution (CES) is one of a suite of technologies we provide our clients to help:

Save water and energy • Reduce hazardous chemical consumption

Ensure employee safety • Protect capital equipment

earthWISE
FULL WATER SOLUTIONS™

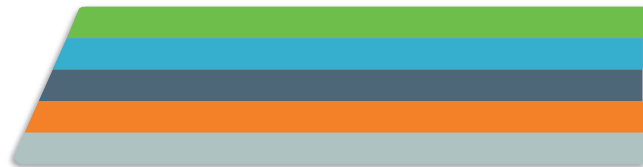

The Chiller Efficiency Solution

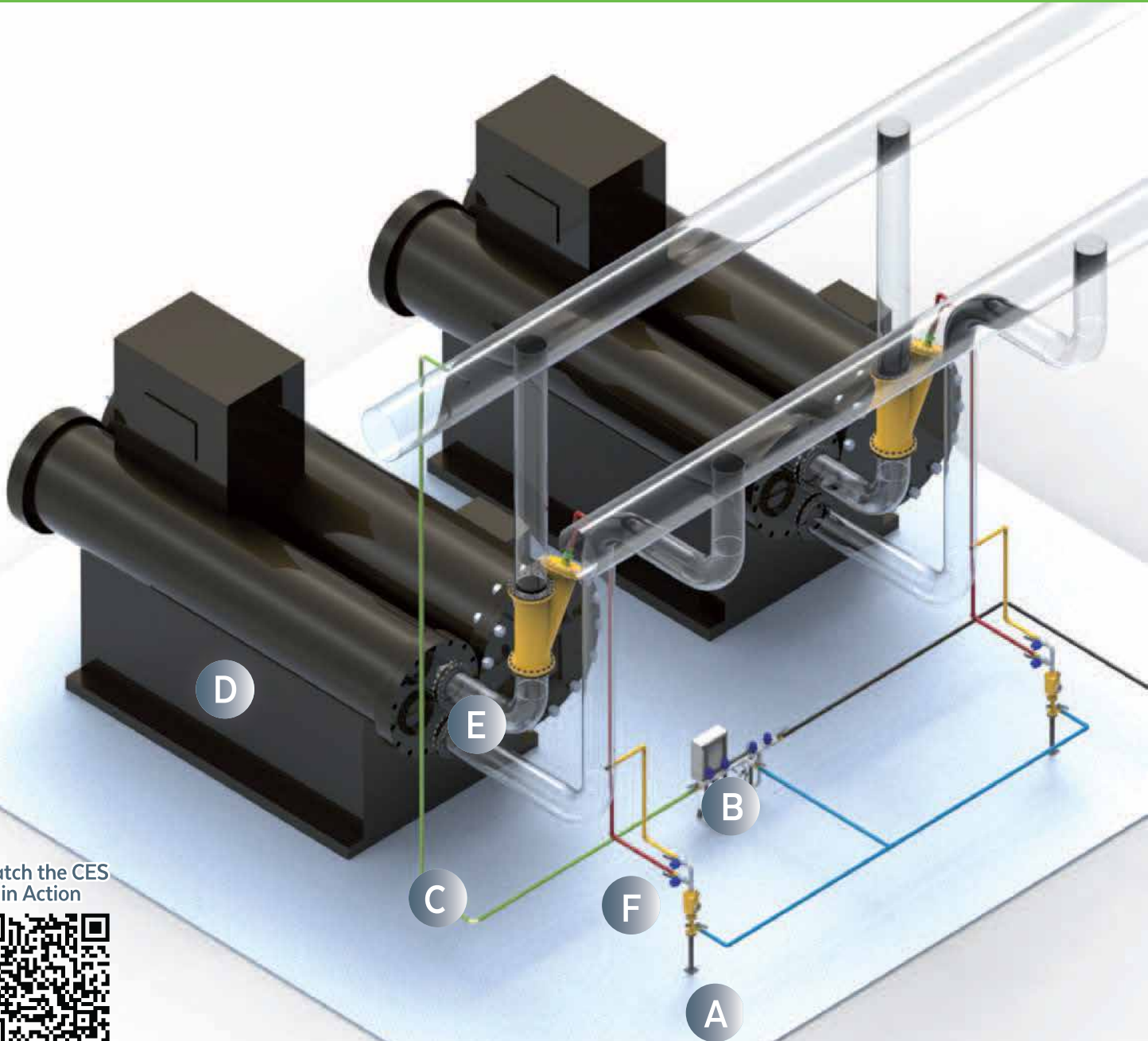

Watch the CES
in Action



The Condenser Tube Cleaning Process

A



Non-abrasive cleaning pods start out in the Pod Storage Unit, connected to the condenser through the main line of the system. A window in the Pod Storage Units allows monitoring of the condition and quantity of pods inside.

B



A PLC controlled pump forces water through the piping loop. Once the water enters the Pod Storage Unit, the system periodically injects the cleaning pods into the inlet pipe. Following injection, normal system water flow carries the pods through the inlet pipe and into the main line.

C

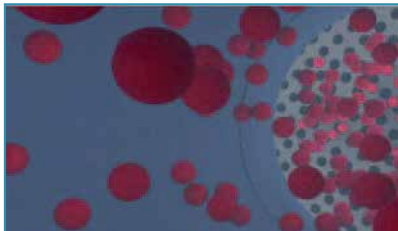

The cleaning pods proceed from the main line to the condenser, where they are randomly distributed across the condenser tubes.

D

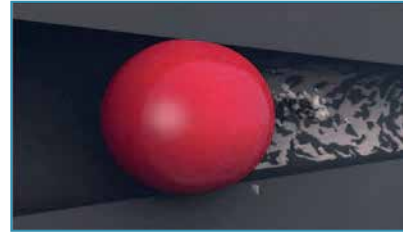

The cleaning pods flow through the tubes at normal system velocity. As water pushes them, residue, deposits and biofilm are removed, leaving clean tubes and optimal heat transfer efficiency.

E

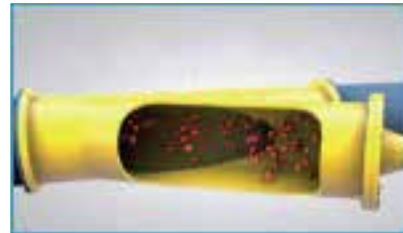

As the cleaning pods exit the condenser, they return to the Pod Collector – a unit designed to collect the pods and prevent re-release into the system, all with no moving parts.

F



Once in the Pod Collector, the controller opens a drain valve and the pods return to the Pod Storage Unit. They are rinsed and held for the next programmed cleaning cycle, set in the PLC by the operator.

Heat Exchanger Fouling



THE ISSUE: HEAT EXCHANGER FOULING

Fouling is any undesirable deposit formed inside the condenser that reduces heat transfer efficiencies (thermal resistance), leading to increased energy consumption. Even well-treated systems experience a gradual buildup of biofilm and debris, resulting in increased energy consumption over time. Conventional tube cleaning involves costly system shutdowns, hazardous chemicals, and lost productivity.

THE SOLUTION: AUTOMATIC ONLINE CLEANING



The blue line represents energy use in a conventional system that requires regular cleanings. The green line shows energy use in the CES system, maintaining efficient energy use over time without cleanings. The red area between the lines is the savings to be had using the CES.

The Earthwise Chiller Efficiency Solution (CES) is remarkably simple: non-abrasive cleaning pods are flushed through the cooling system via natural water flow, ensuring that unwanted deposits and biofilm are removed before fouling can begin.

Installation of the CES is straightforward and guarantees a clean, energy-efficient heat transfer surface. The results are improved heat transfer and reduced energy consumption.

The CES is a fully automated, PLC controlled solution that works continuously while the condenser is operational, eliminating the need for costly shutdowns and cleanings.

The Earthwise Chiller Efficiency Solution: An Exclusive US Offering

Earthwise is proud to partner with CQM, an Israeli company established in 1994 by a multi-disciplinary team of energy and industry experts. The company develops, manufactures, sells and services systems for water conditioning and disinfection. CQM fully complies with the CE directives, ISO 9001:2000, and Green Label Certification standards. Systems are installed worldwide in industrial plants, petrochemical power plants, drinking water facilities, hotels, airports, hospitals, commercial buildings and more.

ABOUT Earthwise Environmental

Robert S. Miller, the current president and sole owner, founded Earthwise Environmental, Inc. in 1995.

His mission was to provide more environmentally friendly methods of treating water.

For over 20 years now, Earthwise has been changing the focus of water treatment technologies to reduce costs, conserve water and eliminate hazardous chemistries. We are a market leader on two fronts:

We work closely with manufacturers in the evaluation of new technologies; and we are a leader in the development of more sustainable custom solutions for industry, commercial properties and healthcare facilities.

www.ChillerEfficiency.com

855-868-8809